

Fitting instructions	
Make:	Jeep
Compass; 2006->	
Patriot; 2007->	
Type:	4525

Permanently
linked to
quality

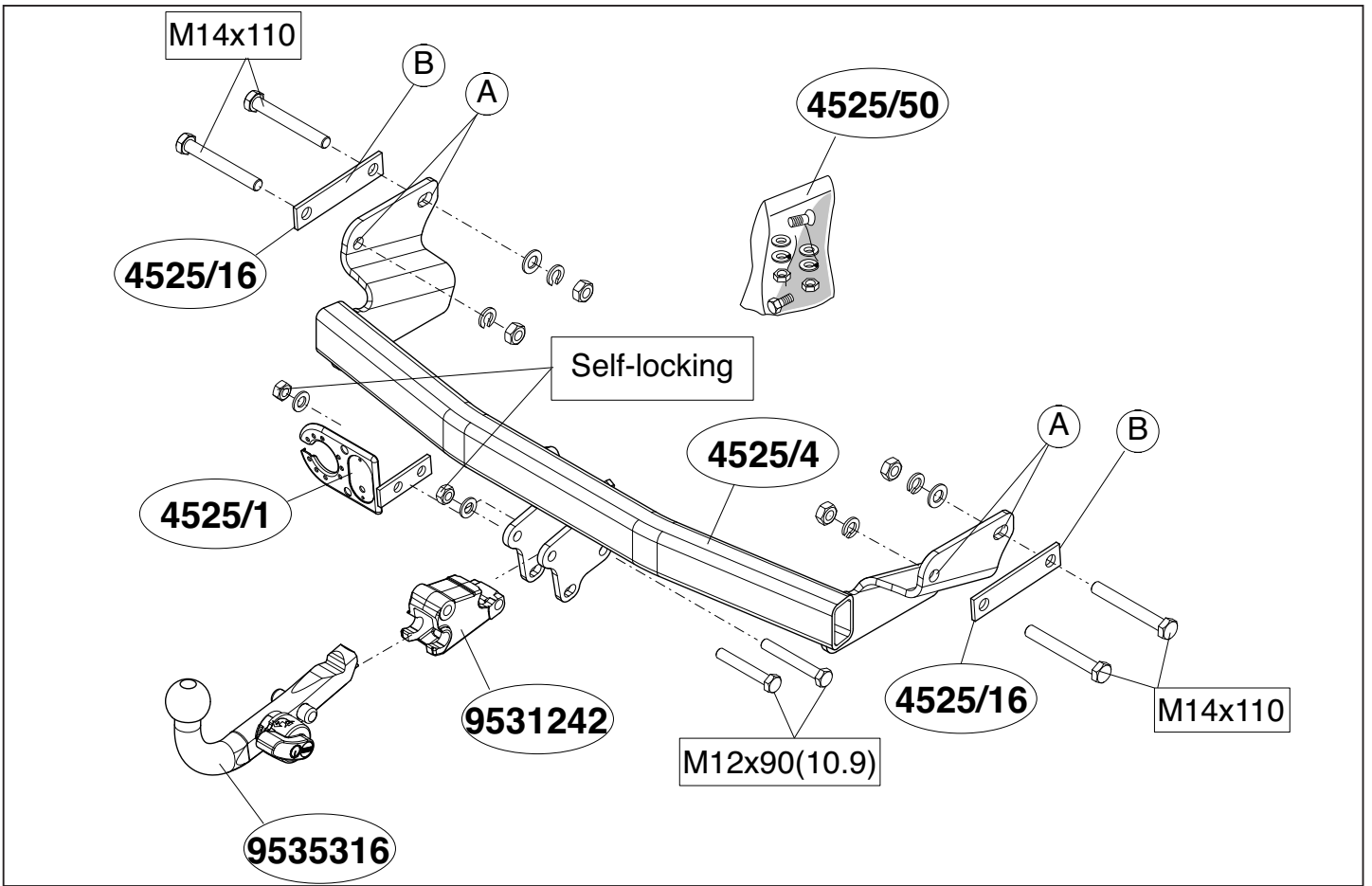

© 452470/24-09-2007/1

(4x) M14

(2x) M12 (10)
self-locking



(4x) M14

(4x) M14

(2x) M12

(4x) M14x10

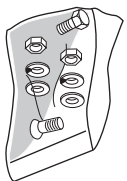
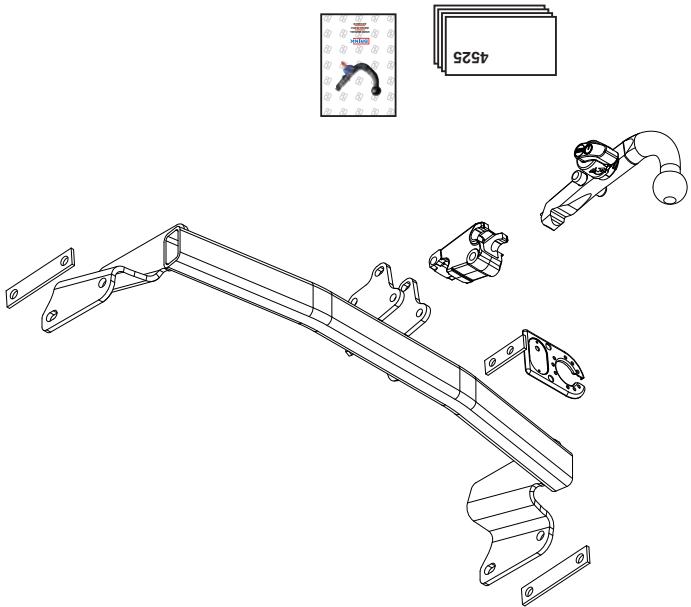
(2x) M12x90 (10.9)

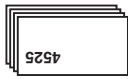
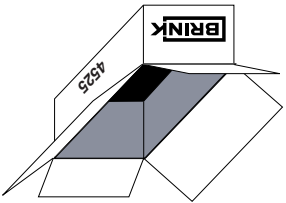

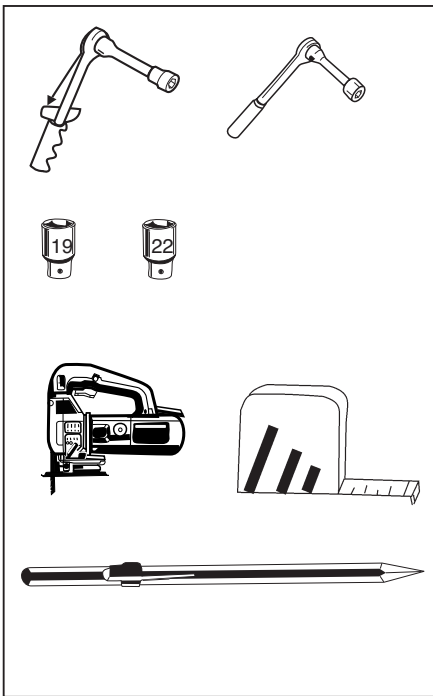
Couplingsclass: A50-X

e11 00-5509

94/20/EC

D-Value :8,7 kN

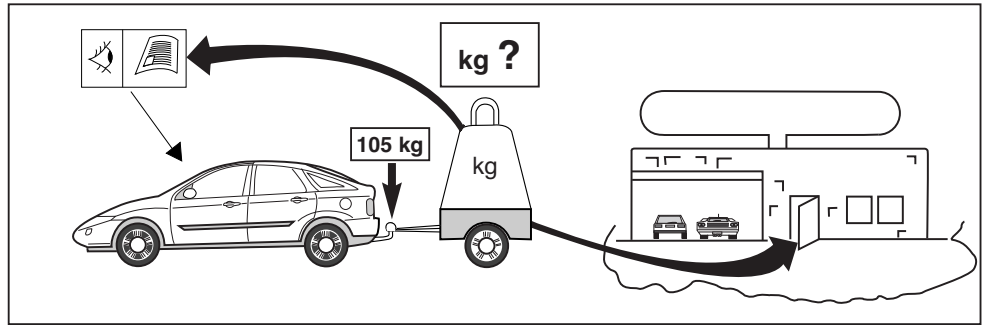

8.8

10.9

8

10

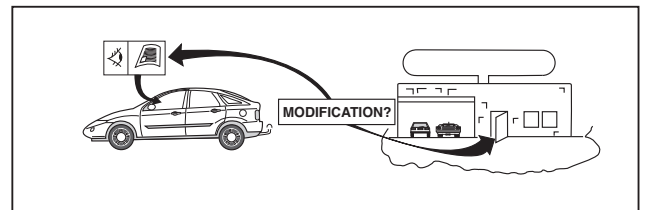

© 452470/24-09-2007/3

Dispositivo di traino tipo: 4525
 Per autoveicoli: Jeep Compass;2006-> / Jeep Patriot; 2007->
 Tipo funzionale:

Classe e tipo di attacco: A50-X
 Omologazione: e11 00-5509
 Valore D: 8,7 kN
 Carico Verticale max. S: 105 kg
 Larghezza rimorchiabile per Caravan e T.A.T.S.: 2,45m vedere CARTA di CIRCOLAZIONE VEICOLO (motrice) + 70 cm = ..arrotondare ai 5 cm superiore (vedi D.M.28/05/85)
 Massa rimorchiabile: vedi carta di circolazione dell' autoveicolo

Per verificare l'idoneità del dispositivo di traino omologato a norma CEE 94/20, all'installazione sulla vettura su cui si intende procedere al montaggio, compilare la seguente formula (se necessario declassare la massa rimorchiabile):

$$D = \frac{T \times C}{T + C} \times 0,00981 \leq 8,7 \text{ kN}$$

dove: T= Massa Complessiva Max. della motrice (in kg)
 C= Massa Rimorchiabile Max. della motrice (in kg)

DA COMPILARE PER IL COLLAUDO

DICHIARAZIONE DI CORRETTO MONTAGGIO: la sottoscritta Ditta dichiara di aver montato in maniera corretta ed in conformi/ alle prescrizioni sia del costruttore del veicolo che del costruttore del dispositivo stesso il seguente dispositivo di attacco meccanico:

tipo:.....
 Il dispositivo di attacco sopra indicato è stato installato su autoveicolo
 modello:.....
 targa:.....
 Data:.....

TIMBRO e FIRMA

Si dichiara inoltre di aver informato l'utente del veicolo sull'USO e MANUTENZIONE del dispositivo stesso.

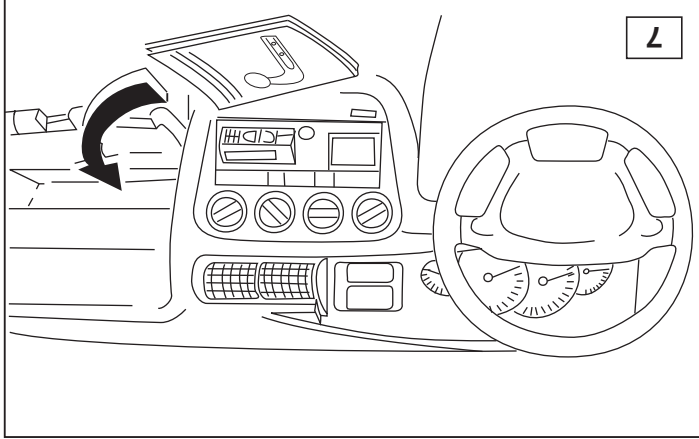
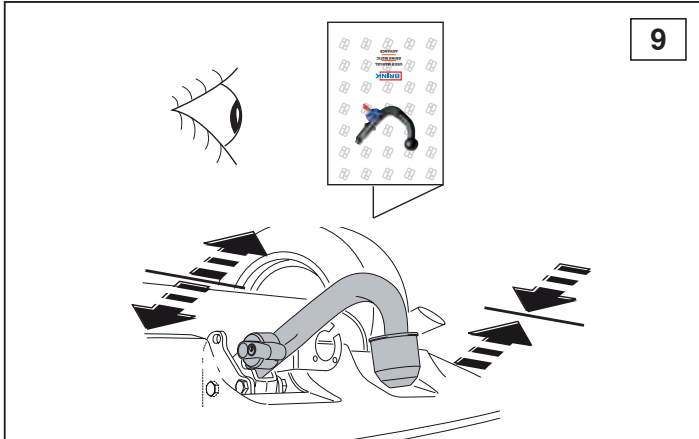

NOTE:

* Should this installation process entail the cutting of the bumper – conformation MUST be obtained by the installation engineer of the customer's acceptance prior to completion. Thule Towing Systems do not accept responsibility for any matters arising as a result of this miscommunication.

All measurements are in mm!

HINWEISE:

* Die für das Fahrzeug zugelassene Anhängelast ist den Fahrzeug Unterlagen zu entnehmen. Bei Änderungen des Fahrzeuggewichtes muß die höchstzulässige Anhängelast gegebenenfalls aus dem D-Wert nachgerechnet werden.
 * Elektrische Anlage gemäß SIVZO anbringen.
 * Auskunft hierüber kann Ihr Fachhändler oder der TÜV geben.

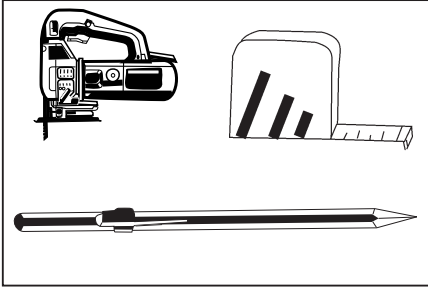

Use Template 4525 COMPASS

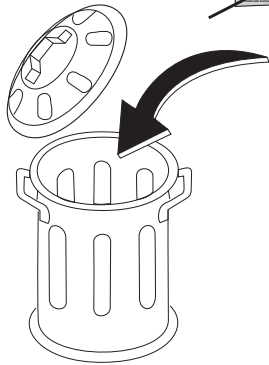
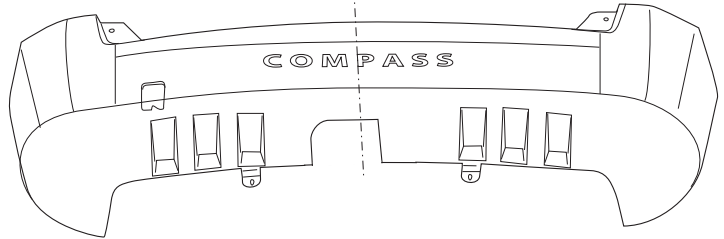
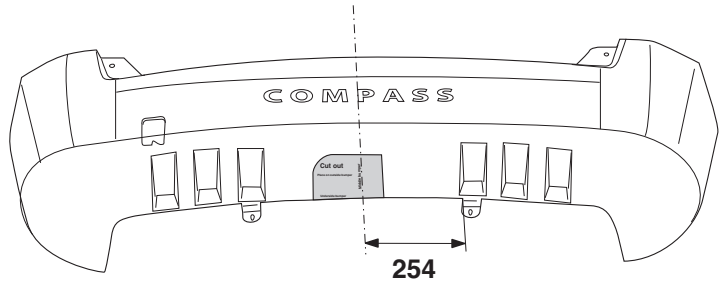

1

© 452470/24-09-2007/5

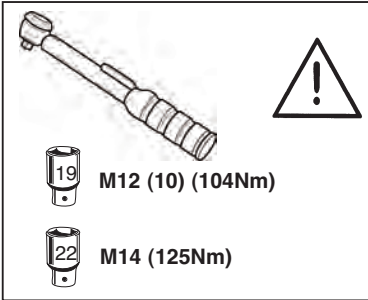

19 M12 (10) (104Nm)

22 M14 (125Nm)

PUSH **1**

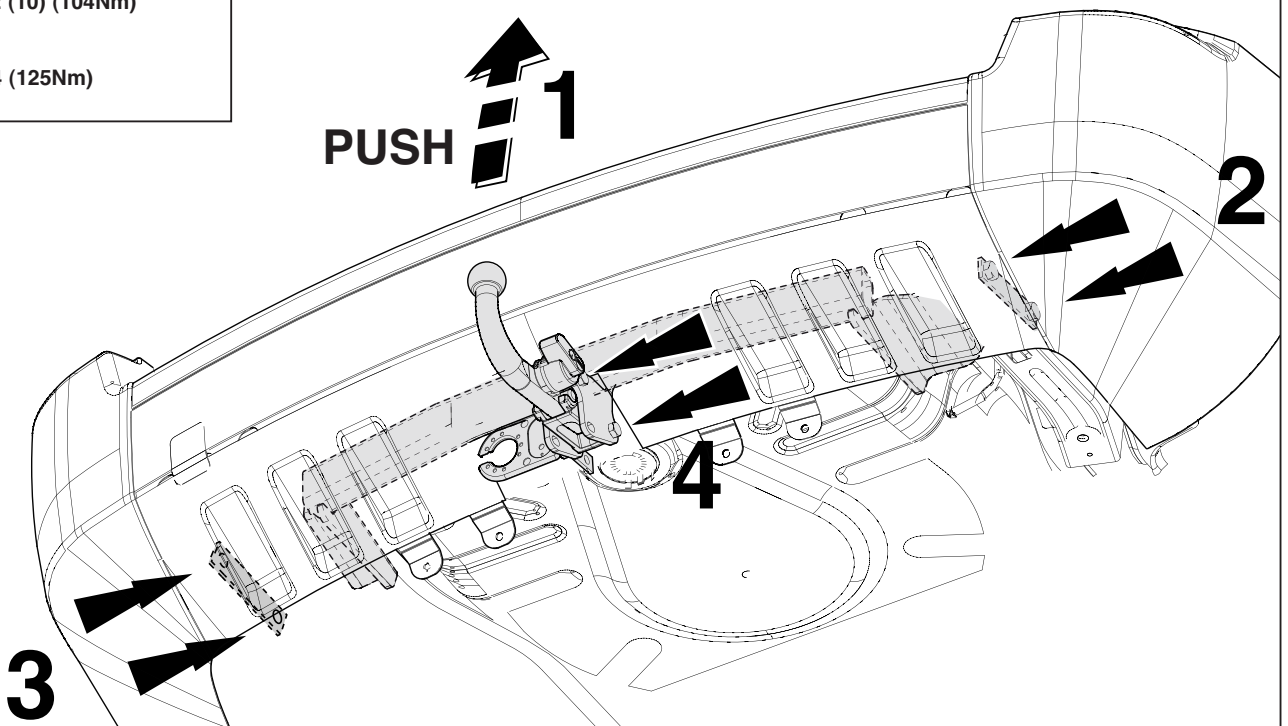

5

© 452470/24-09-2007/10

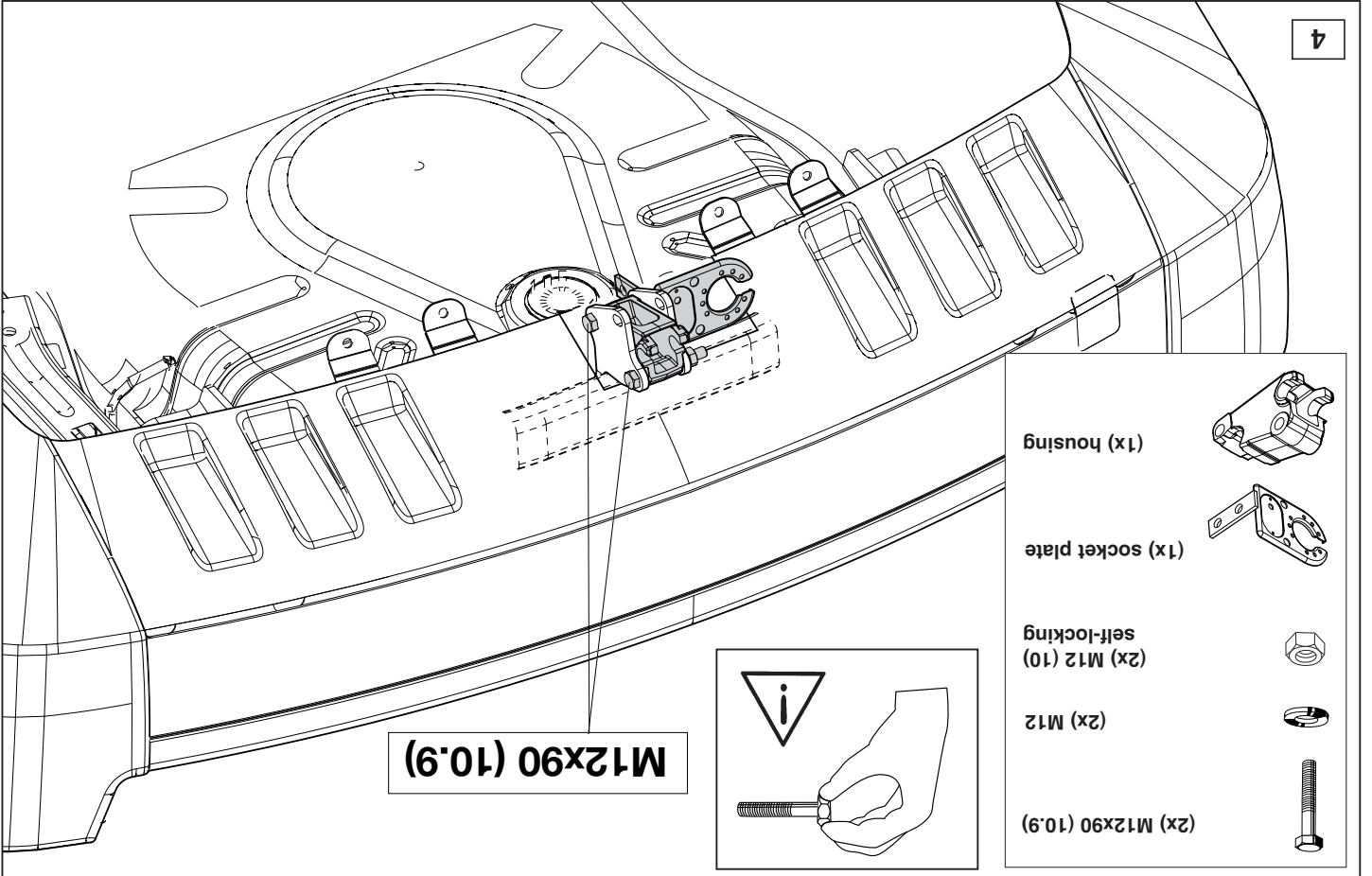
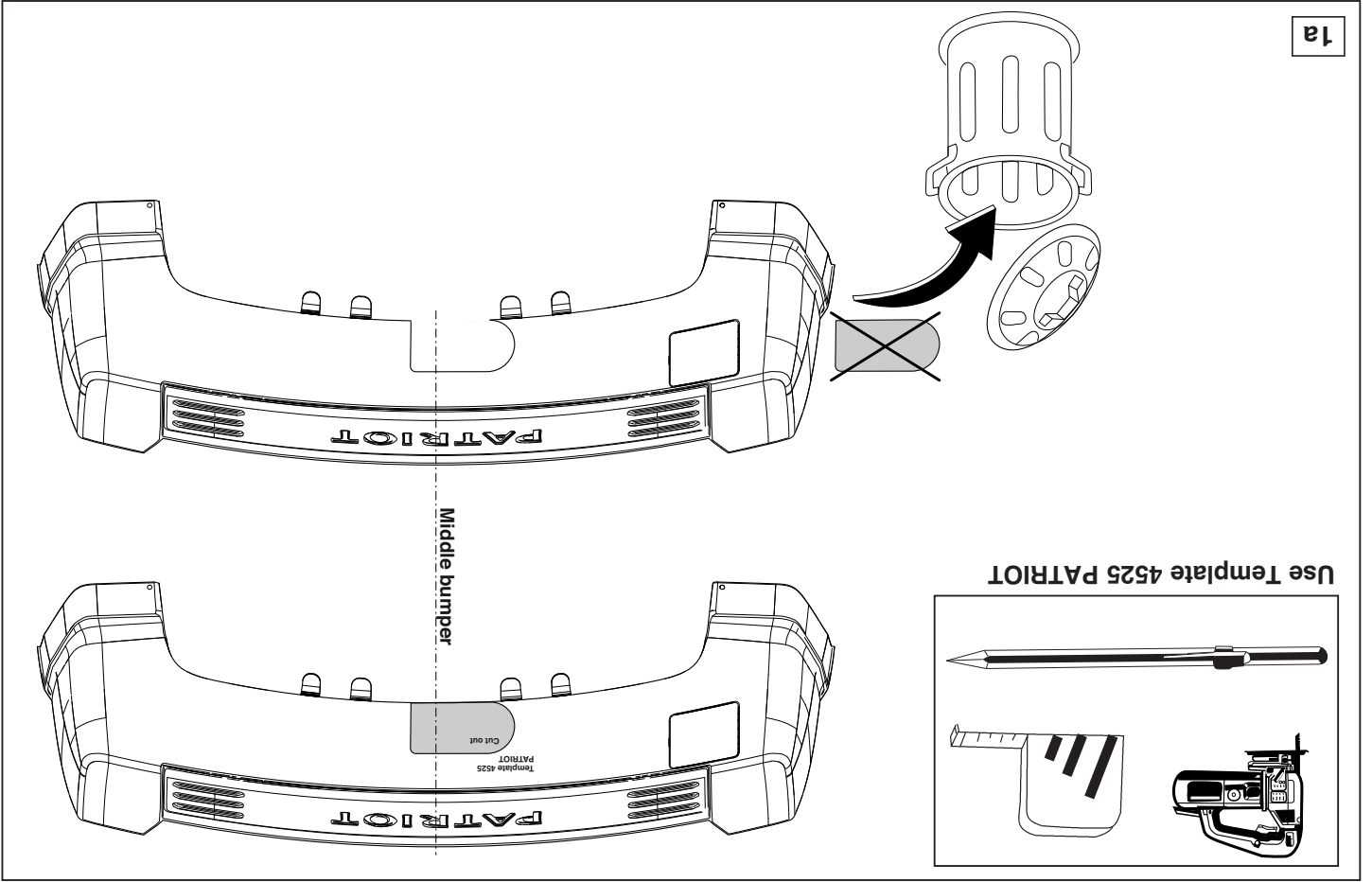

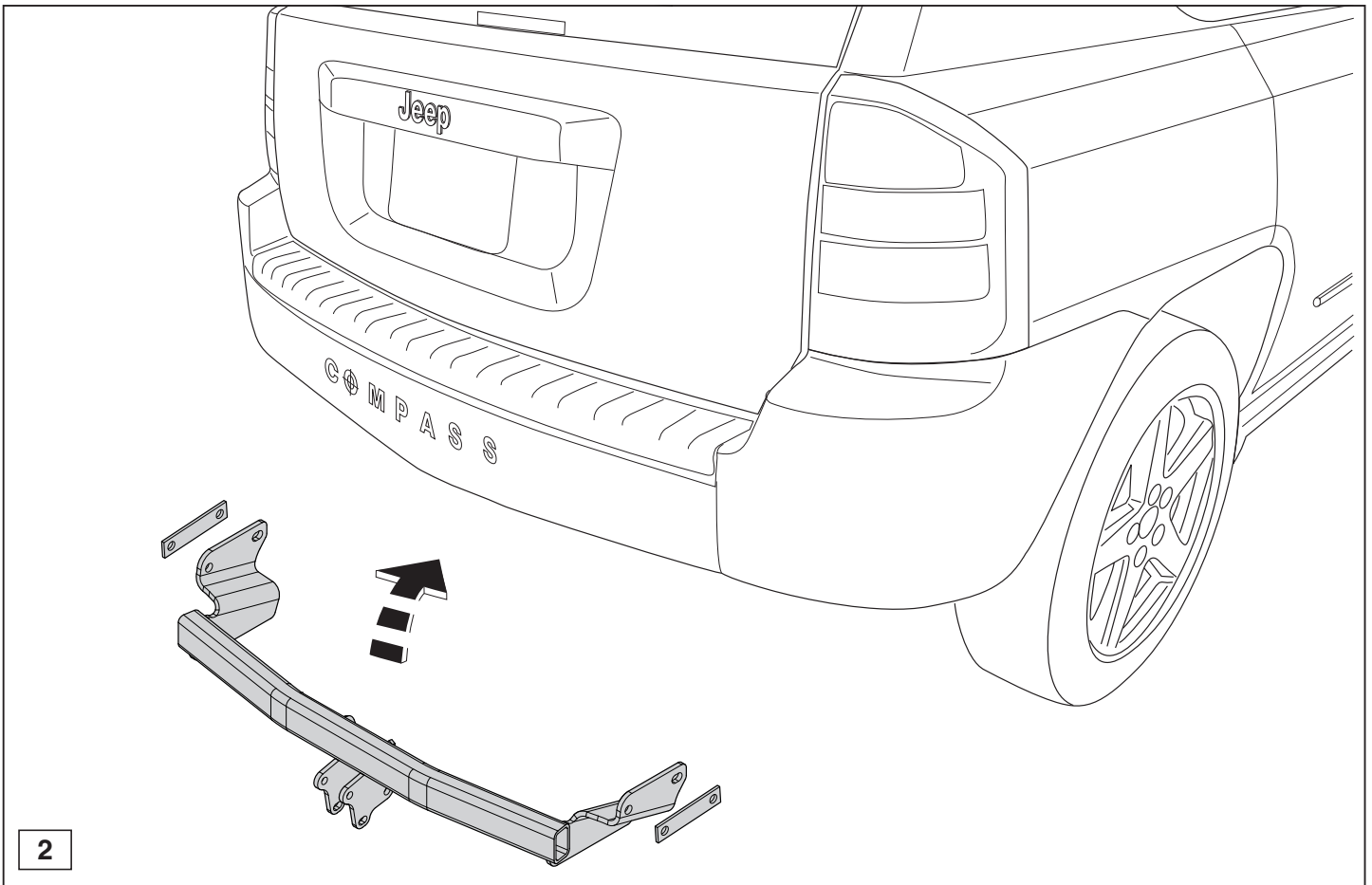

2

© 452470/24-09-2007/7

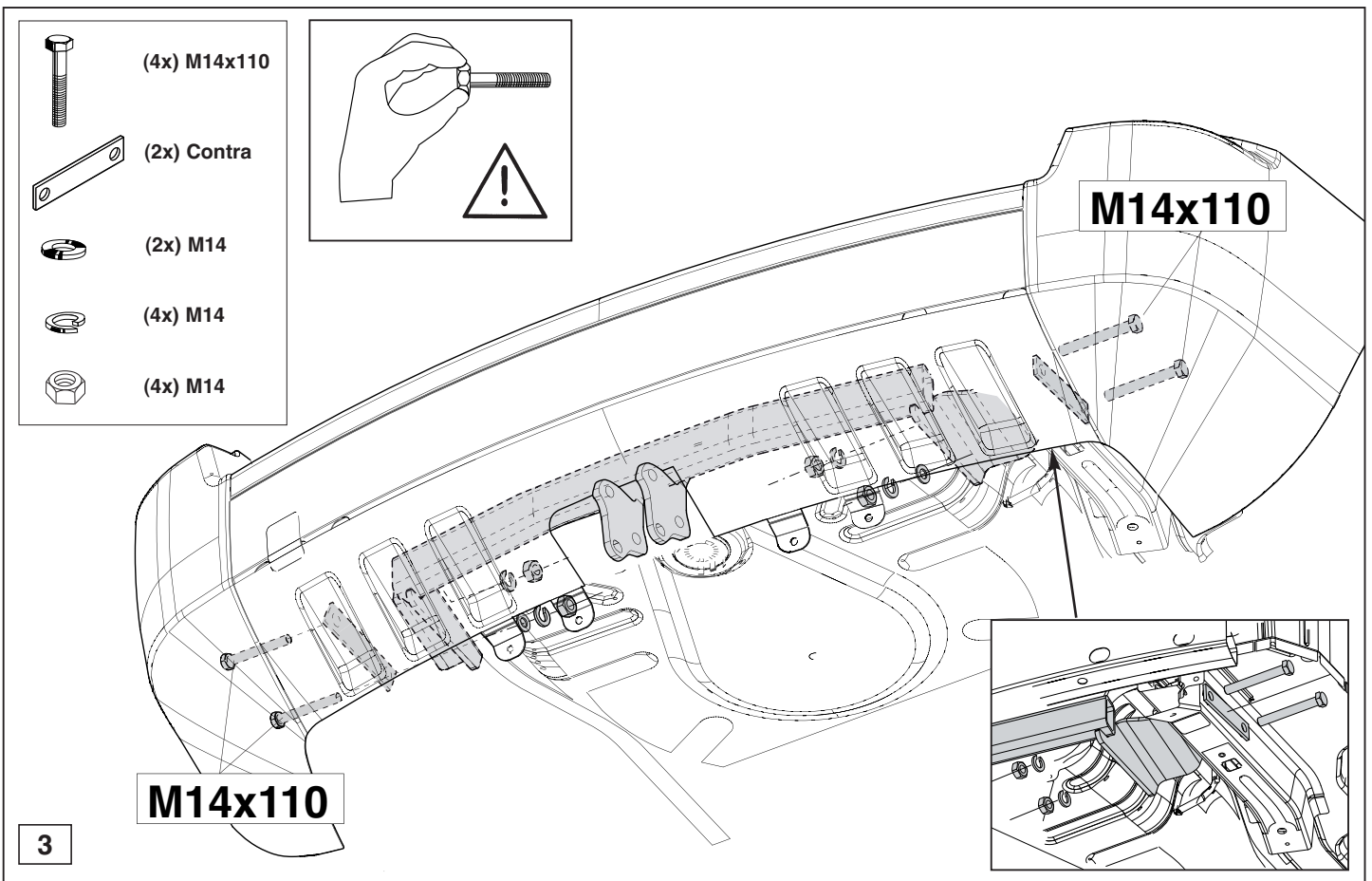

© 452470/24-09-2007/8